



# FITTING INSTRUCTIONS

BMW F800 GS (24-26) NTR ADV R3 SHOCK WITH HPA



# FITTING INSTRUCTIONS

BMW F800 GS (24-26)  
NITRON ADV R3 SHOCK WITH HPA  
NTBKW78\_



## INSTALL NOTES:

The shock should be installed with the piggyback reservoir facing the right hand side and the hydraulic preload hose exiting on the left hand side of the shock body. Route the hose over the top of the shock body and across to the right hand side. The hydraulic adjuster body is mounted using the supplied bracket between the subframe and rear most exhaust hanger bolt as shown. Install the spacer to the front most bolt to space the exhaust bracket squarely. Secure the hose to the subframe using the mounts and zip ties.

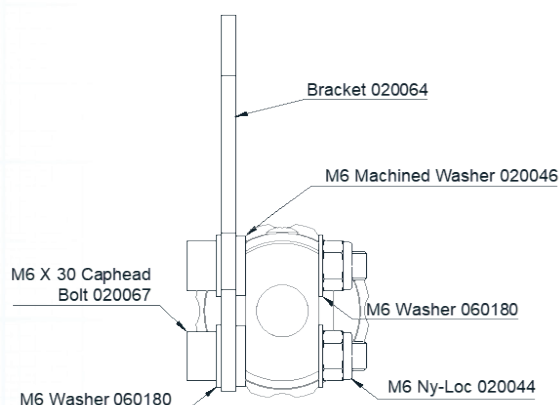
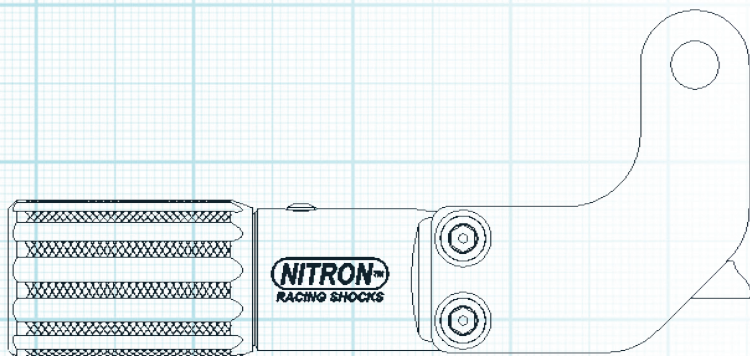

For more information, get in contact  
+44 (0)1993 849 449 | +1 (951) 696-1111 | [sales@nitron.com](mailto:sales@nitron.com)